

A

B

C

D

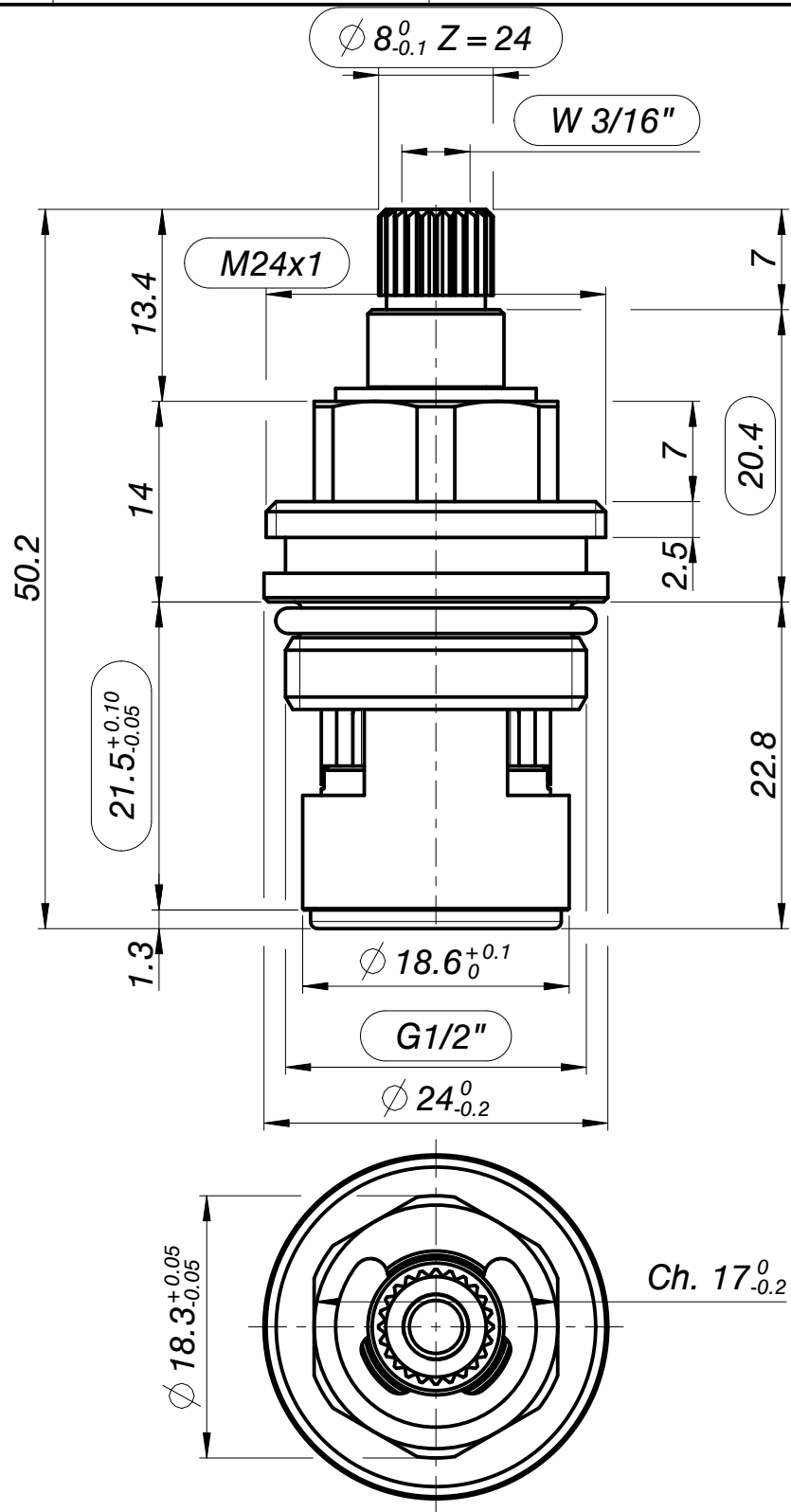

DRAWING NAME: ST105BMAG118100-COM

D	---	----	---	G	---	----	---
C	---	----	---	F	---	----	---
B	---	----	---	E	---	----	---
Rev.	Date	Description	Des.	Rev.	Date	Description	Des.



Studio Tecnico Sviluppo e Ricerche S.r.l. Societa' a socio unico
 Via Milano, 7/5 - 20084 - Lacchiarella (MI) -
 Tel. +39 02 90076832 - Fax +39 02 9007569

Description:		-		Scost. x plastiche (stampaggio)	Secondo DIN 16901	Mat.		VEDI TABELLA	
VITONE G1/2" 90° Sx API/ORARIA A/RUM. ASTA PERS.		-		Scost.x ceramiche	Quote senza toll.za: ±1% Toll. minima: ±0.1mm Toll. angolare: ±1°	Treat.		----	
		-		Scost.x gomme Scost.x ORing	Secondo ISO 3302 Secondo ISO 3601	Weight:		61.839 gr.	
-----		-		Scost. generici	±30' ±0.05 ±0.1 ±0.2	Date: 23-05-2017		Scale: 2:1	
Drawn by:		Verified by:		Approved by:		Detail		Rev.	
R. Sacchetti		_____		D.F.		ST105BMAG118100		A	
Tolleranze generali									